

ATI3A-ATI3A

ATTACCHI SPECIFICI PER - SPECIFIC FITTING KIT FOR
 KIT DE MONTAGE SPECIFIQUE POUR - SPEZIFISCHER MONTAGEKIT FÜR
 ANCLAJE ESPECIFICO PARA

PIAGGIO LIBERTY S 2006

50/125/200cc

ISTRUZIONI DI MONTAGGIO - MOUNTING INSTRUCTIONS
 INSTRUCTIONS DE MONTAGE - BAUANLEITUNG - INSTRUCCIONES DE MONTAJE

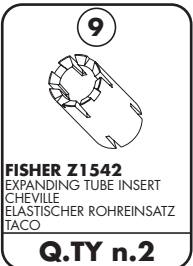
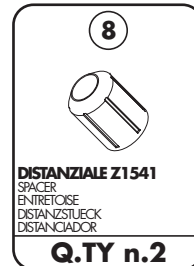
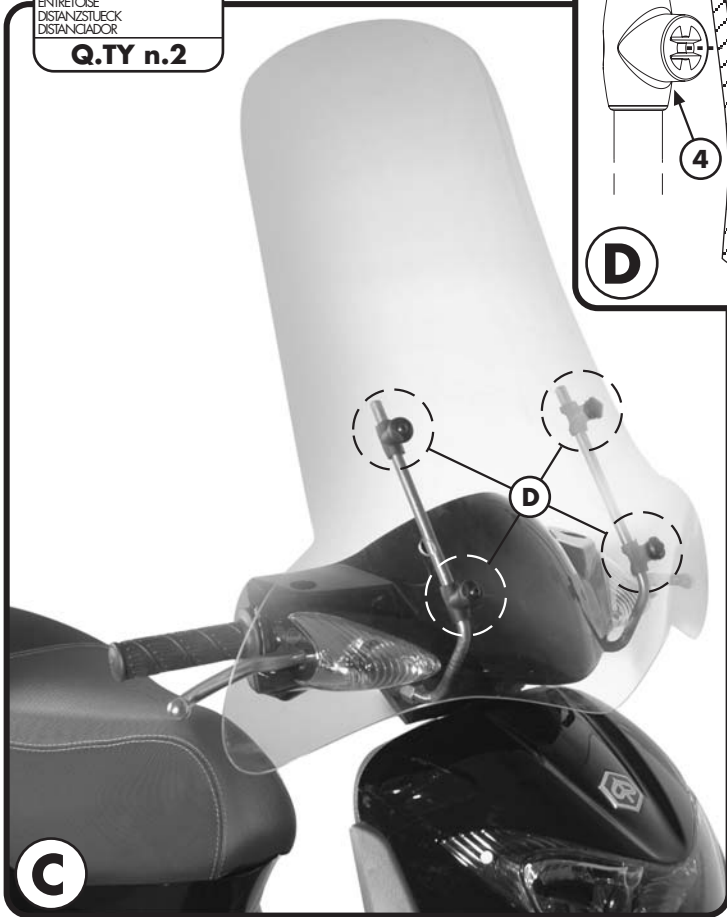
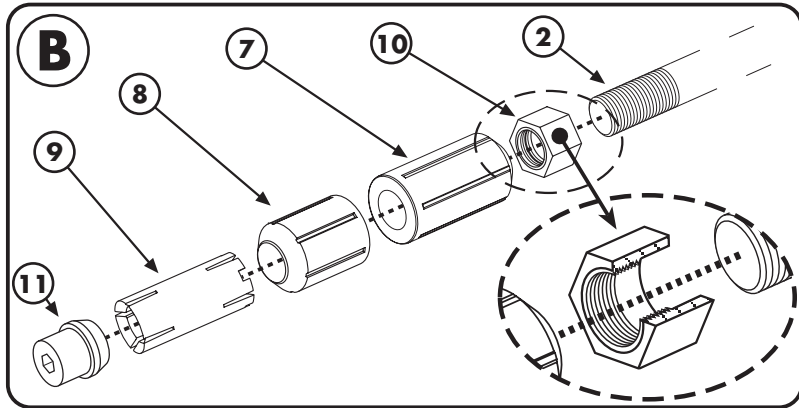
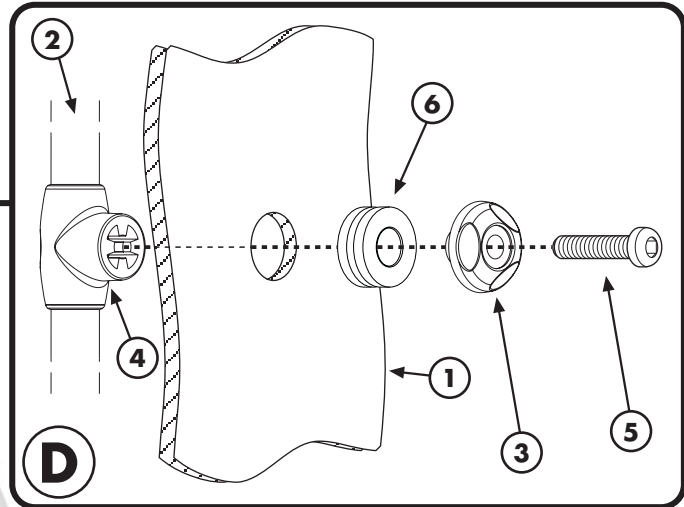
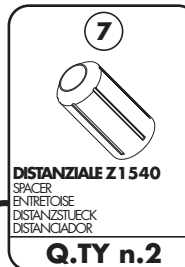
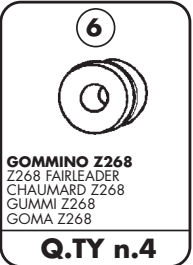
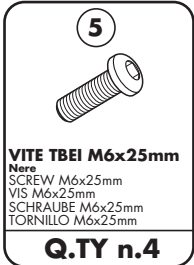
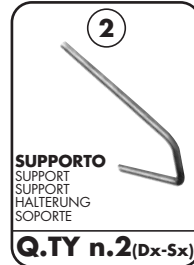
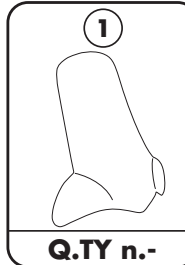

A113A - A113A

ATTACCHI SPECIFICI PER - SPECIFIC FITTING KIT FOR
KIT DE MONTAGE SPECIFIQUE POUR - SPEZIFISCHER MONTAGEKIT FÜR
ANLAJE ESPECÍFICO PARA

PIAGGIO LIBERTY S 2006
50/125/200cc

ISTRUZIONI DI MONTAGGIO - MOUNTING INSTRUCTIONS
INSTRUCTIONS DE MONTAGE - BAUANLEITUNG - INSTRUCCIONES DE MONTAJE

I ISTRUZIONI DI MONTAGGIO

1. ASSEMBLARE I SUPPORTI N°2 AGLI ALTRI COMPONENTI, ILLUSTRAZIONE B; FARE PARTICOLARE ATTENZIONE ALL'ORIENTAMENTO DI MONTAGGIO MOSTRATO IN FIGURA B DEL PARTICOLARE N°10;
ATTENZIONE: SERRARE BENE IL PARTICOLARE N°11 E LASCIARE MORBIDO IL PARTICOLARE N°10;
2. PROCEDERE QUINDI NEL MONTAGGIO MOSTRATO IN FOTOGRAFIA A INFILANDO I SUPPORTI COSÌ COMPOSTI NEL FORO PREDISPOSTO NEL MANUBRIO DELLO SCOOTER;
3. DOPO AVER POSIZIONATO CORRETTAMENTE I SUPPORTI SERRARE IL PARTICOLARE N°10;
3. MONTARE IL PARABREZZA (NON INCLUSO) COME MOSTRATO IN FOTOGRAFIA C;
4. ULTIMARE IL MONTAGGIO CONTROLLANDO CHE TUTTE LE VITI SIANO SERRATE BENE.

GB MOUNTING INSTRUCTIONS

1. ASSEMBLE AND MOUNT SUPPORTS N°2 TOGETHER WITH THE OTHER COMPONENTS, AS IN PICTURE B; PAY ATTENTION TO THE POSITIONING OF PART N°10 AS INDICATED IN PICTURE B;
ATTENTION: TIGHTEN PART N°11 AND LEAVE PART N°10 LOOSE;
2. PROCEED WITH THE MOUNTING SHOWN IN PICTURE A BY INSERTING THE SUPPORTS IN THE HOLE PLACED ONTO THE SCOOTER HANDLEBAR;
3. AFTER POSITIONING CORRECTLY THE SUPPORTS, TIGHTEN PART N°10;
4. LASTLY CHECK THAT ALL SCREWS HAVE BEEN TIGHTENED.

F INSTRUCTIONS DE MONTAGE

1. ASSEMBLER LES SUPPORTS N°2 AUX AUTRES COMPOSANTS, CROQUIS B ; FAIRE PARTICULIÈREMENT ATTENTION AU SENS DE MONTAGE DE LA PIÈCE N°10 MONTRÉ AU CROQUIS B ;
ATTENTION : BIEN SERRER LA PIÈCE N°11 ET LAISSER LIBRE LA PIÈCE N°10 ;
2. PROCEDER AU MONTAGE MONTRÉ EN PHOTO A EN ENFILANT LES SUPPORTS COMPOSÉS PRÉCÉDEMMENT DANS LES TROUS PRÉVUS AU GUIDON DU SCOOTER ;
3. APRES AVOIR POSITIONNER CORRECTEMENT LES SUPPORTS, SERRER LES PIÈCES N°10 ;
4. MONTER LE PARE-BRISE (NON INCLUS) COMME MONTRÉ EN PHOTO C ;
5. TERMINER LE MONTAGE EN CONTROLANT LE BON SERRAGE DE TOUTES LES VIS.

D BAUANLEITUNG

1. MONTIEREN SIE DIE HALTERUNGEN NR. 2 MIT DEN ANDEREN TEILEN ZUSAMMEN, BILD B; BEACHTEN SIE DIE POSITION DES TEILES NR. 10 WIE IM BILD B BESCHRIEBEN;
ACHTUNG: ZIEHEN SIE DAS TEIL NR. 11 FEST UND LASSEN SIE DAS TEIL NR. 10 LOCKER;
2. GEHEN SIE MIT DER MONTAGE VOM BILD A WEITER UND STECKEN SIE DIE HALTERUNGEN IN DAS LOCH AUF DEM ROLLERLENKER;
3. NACHDEM SIE DIE HALTERUNGEN KORREKT POSITIONIERT HABEN, ZIEHEN SIE DAS TEIL NR. 10 FEST;
4. MONTIEREN SIE DAS WINDSCHILD (NICHT VORHANDEN) WIE IM BILD C BESCHRIEBEN;
5. ZULETZT ÜBERPRÜFEN SIE, DASS ALLE SCHRAUBEN FESTGEZOGEN WURDEN.

ES

INSTRUCCIONES DE MONTAJE

1. JUNTAR EL SOPORTE N°2 A LOS OTROS COMPONENTES , ILLUSTRACIÓN B; PRESTAR ESPECIAL ATENCIÓN A LA ORIENTACIÓN DEL MONTAJE MOSTRADO EN LA FIGURA B , EN PARTICULAR, EL N°10;
ATENCIÓN: APRETAR BIEN EL ARTICULO N°11 Y DEJAR SUAVE EL TORNILLO N°10.
2. SEGUIR CON EL MONTAJE MOSTRADO EN LA FOTOGRAFIA A INTRODUCIENDO EL SOPORTE EN EL AGUJERO SITUADO EN EL MANILLAR.
3. DESPUÉS DE HABER POSICIONADO CORRECTAMENTE EL SOPORTE APRETAR EL TORNILLO N°10;
4. MONTAR EL PARABRISAS (NO INCLUIDO) COMO SE MUESTRA EN LA FOTOGRAFIA C.
5. TERMINA EL MONTAJE CONTROLANDO QUE TODOS LOS TORNILLOS ESTÉN BIEN APRETADOS.