

# ANBAUANLEITUNG

mounting instructions • instructions de montage • instrucciones de montaje • istruzioni di montaggio

## **TRT.00.787.34700/B**

beinhaltet • contains • contient • contiene • contiene

TRT.00.787.32100/B

TRT.00.787.10100/B

TRT.00.787.80000/B

Item number: TRT.00.787.32100/B

Revision: 00 · Date: 12 - 2022

## PRO tank ring

 ~ 0.5 h.

EASY      DIFFICULT

**ENGLISH** Thank you for choosing this premium product from SW-MOTECH. Visit our online shop for more information (e.g. model assignments). Required documents (e.g. national type approval) are available there for you to download.

Please read and understand all the instructions, safety information and warnings in these mounting instructions before mounting and using the product in order to avoid injury and damage. Keep these mounting instructions for reference.

This product was developed for vehicles in factory condition. Compatibility with original accessories or accessories from other manufacturers cannot be guaranteed.

These mounting instructions have been prepared to the best of our current knowledge. No legal claims relating to accuracy can be made. Errors and omissions excepted. We reserve the right to make technical and design changes. The copyright is held by SW-MOTECH.

### SAFETY WARNING SYMBOL

 This warning symbol is used in these mounting instructions to warn of deadly dangers, injuries or other hazards. The words **DANGER**, **WARNING** or **CAUTION** are used as part of this warning symbol to convey important safety messages and information relating to the installation and use of this product. These words, together with the safety warning symbol, mean:

 **DANGER:** Indicates a hazardous situation which, if not avoided, will result in death or serious injury!

 **WARNING:** Indicates a hazardous situation which, if not avoided, may result in death or serious injury!

 **CAUTION:** Indicates a hazardous situation which, if not avoided, may result in minor or moderate injury!

 **NOTE:** Important information, but not relating to a risk of death or injury (property damage only)!

### GENERAL INFORMATION

 **WARNING:** Assembly and/or maintenance of this product requires advanced technical skill, appropriate tools, and a good understanding of tool usage and torque specifications. For your own safety, SW-MOTECH recommends having the assembly and/or maintenance carried out by a qualified and certified motorcycle workshop.

 **WARNING:** If you do choose to assemble this product yourself, carefully and fully read the mounting instructions before assembly and use, and follow all instructions to avoid serious injury or death. Also observe all relevant information in the vehicle manual when mounting or using the product. IF YOU DO NOT UNDERSTAND ANY PART OF THESE MOUNTING INSTRUCTIONS OR NEED AN EXPLANATION AS TO A SPECIFIC INSTRUCTION, DO NOT ATTEMPT TO INSTALL THIS PRODUCT WITHOUT CONSULTING SW-MOTECH FOR ASSISTANCE!

**PREPARATION:** Read the mounting instructions carefully and make sure that all parts on the parts list are available.

 **CAUTION:** Ensure that your vehicle is standing securely. Switch off the engine and remove the ignition key. Allow the engine/exhaust to cool down if necessary. Disconnect the battery when working on the electrical system. Only use proper tools and always wear safety goggles and gloves during assembly and maintenance. Have a second person help you with assembly and maintenance.

**ASSEMBLY:** All parts and connections removed from the vehicle must be reinstalled according to the vehicle manufacturer's specifications or replaced with parts and hardware supplied by SW-MOTECH.

 **WARNING:** Secure all threads with a medium-strength liquid threadlocker, unless otherwise specified.

 **DANGER:** Tightening torques not defined by SW-MOTECH must be obtained from the vehicle manufacturer or a certified motorbike workshop.

**FUNCTIONAL CHECK:** After mounting the product, ensure that no moving parts are obstructed and that the function of the vehicle is not impeded. Cables and hoses must not rub against each other and/or be hindered in any way.

 **WARNING:** Carry out a comprehensive functionality check before you start to drive. Check the tightening torque of all connections and the tight fit of the product after the first 50 km and then at regular intervals. Mounted accessories can change the handling and stability of the vehicle.



SW-MOTECH GmbH & Co. KG  
Ernteweg 7-10  
35282 Rauschenberg  
Germany



 [info@sw-motech.com](mailto:info@sw-motech.com)  
 [www.sw-motech.com](http://www.sw-motech.com)

**LEGEND OVERVIEW - READ AND KEEP MOUNTING INSTRUCTIONS!**



Take note of the symbols and what they mean in the ASSEMBLY section. If the term OEM appears in the ASSEMBLY section, the vehicle manufacturer's specifications must be observed and applied.



If you have any questions, please don't hesitate to contact our Customer Service team or our distributors. You can find our telephone number and a list of our distributors in our online shop:

**[www.sw-motech.com](http://www.sw-motech.com)**



**Use thread locker:** Indicates that a thread must be coated with liquid thread locker. H (HIGH): high strength; M (MEDIUM): medium strength; L (LOW): low strength.



**Tighten/note the tightening torque information:**

Indicates the tightening torque of a part specified by SW-MOTECH or the vehicle manufacturer (OEM).

**PARTS LIST - READ AND KEEP MOUNTING INSTRUCTIONS!**

**2**

**1**



TRT.08.640.002.49

 **1/1**

**2**



M3 x 8; DIN 7991  
SC.ST.03.008.45.7991.088

 **2/2**

**4**

**3**



TRT.00.787.900.03.02

 **1/1**

**4**



TRT.00.787.900.05.35

 **1/1**

**5**



M5 x 12; DIN 7991  
SC.ST.05.012.45.7991.088

 **2/2**

**6**



M5 x 16; DIN 912  
SC.ST.05.016.45.912.088

 **2/2**

**7**



TRT.00.787.022.48

 **2/2**

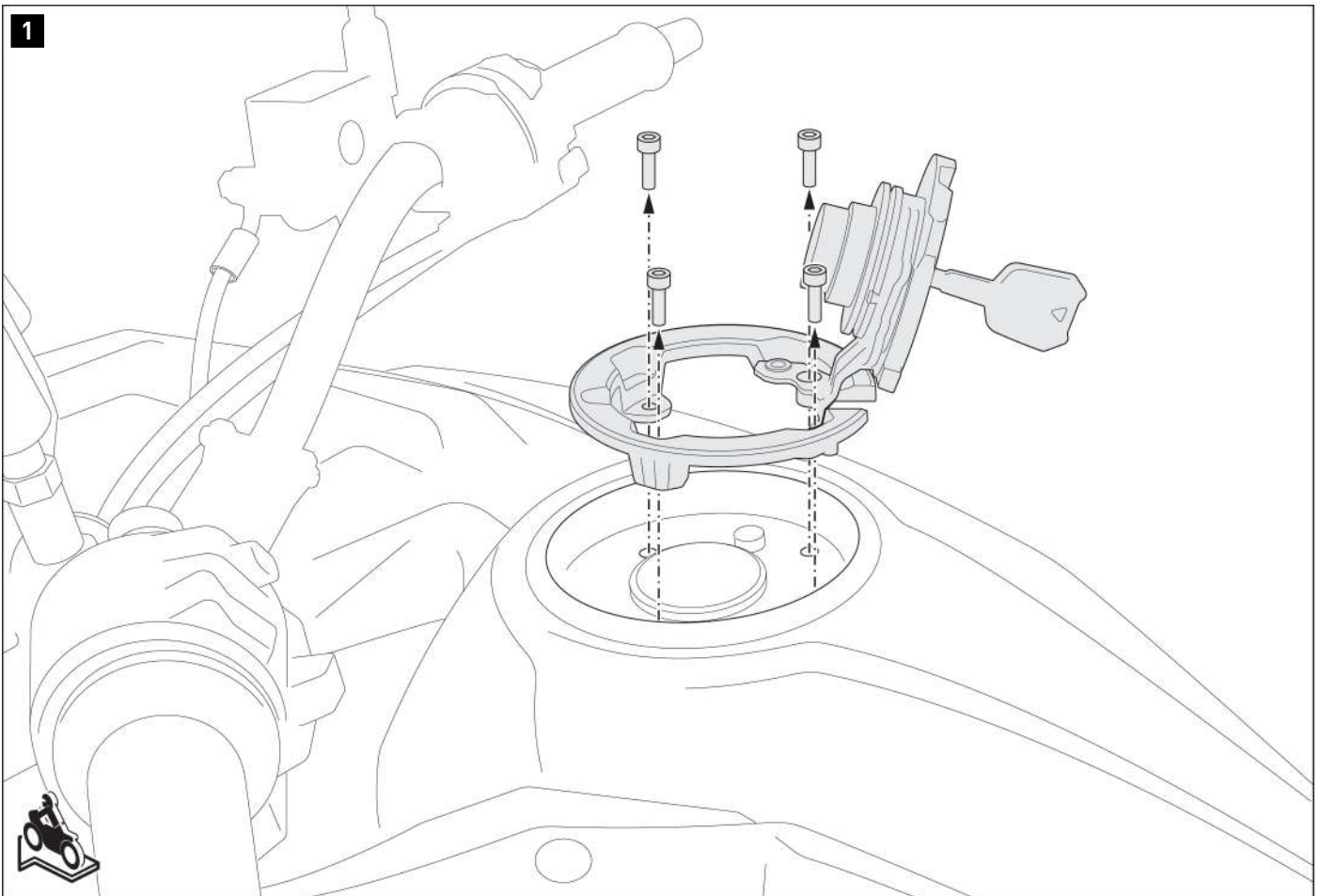

FIDLOCK®-licensed technology,  
patent pending; no. 102019215277.5

**▲WARNING: Always wear eye and hand protection!**  
**▲WARNING: Always use appropriate tools!**

Open the cap and undo the screws.

Remove the cap unit from the vehicle.  
Plug the tank opening with a cloth.

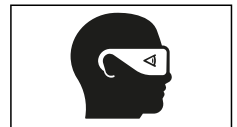

2

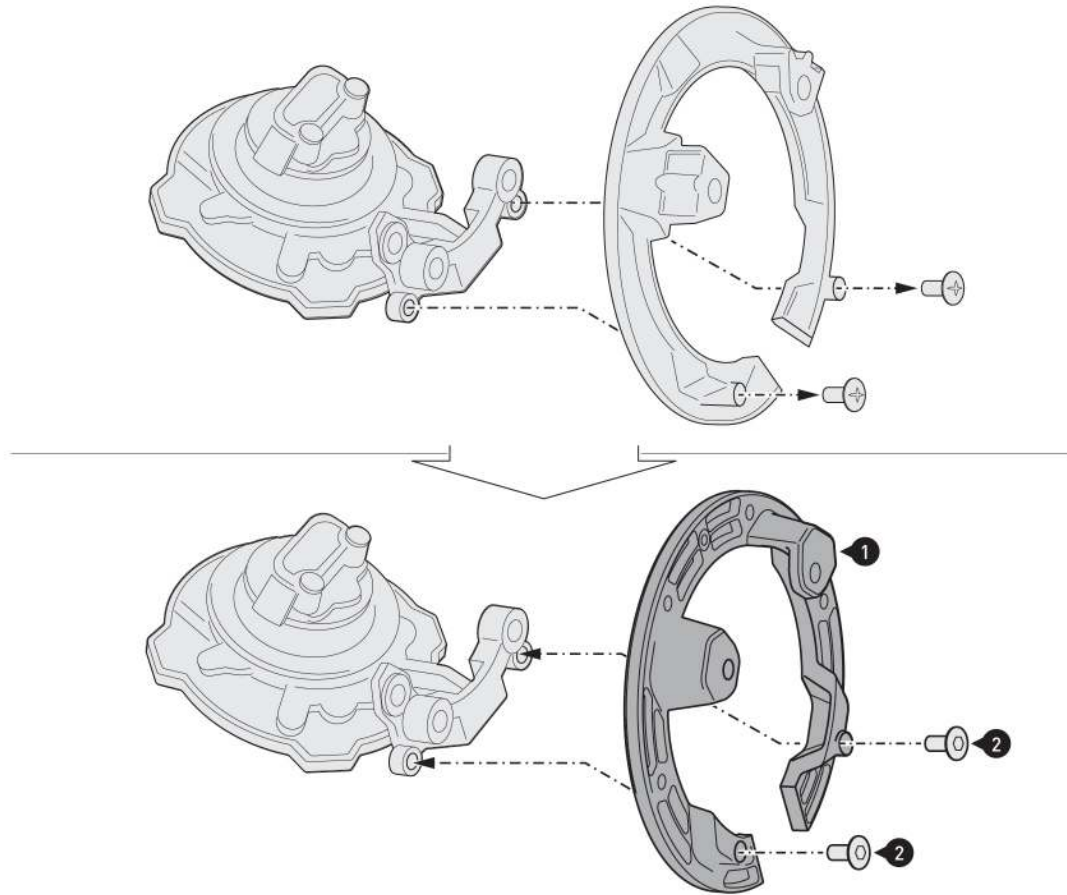

Unscrew the screws from the cap unit.

Screw the tank ring adaptor (1) onto the cap.

**▲ WARNING: Use liquid thread locker!**  
Tighten the screws as specified in the instructions.



M 1.5 Nm

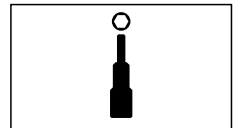
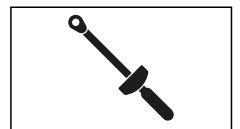

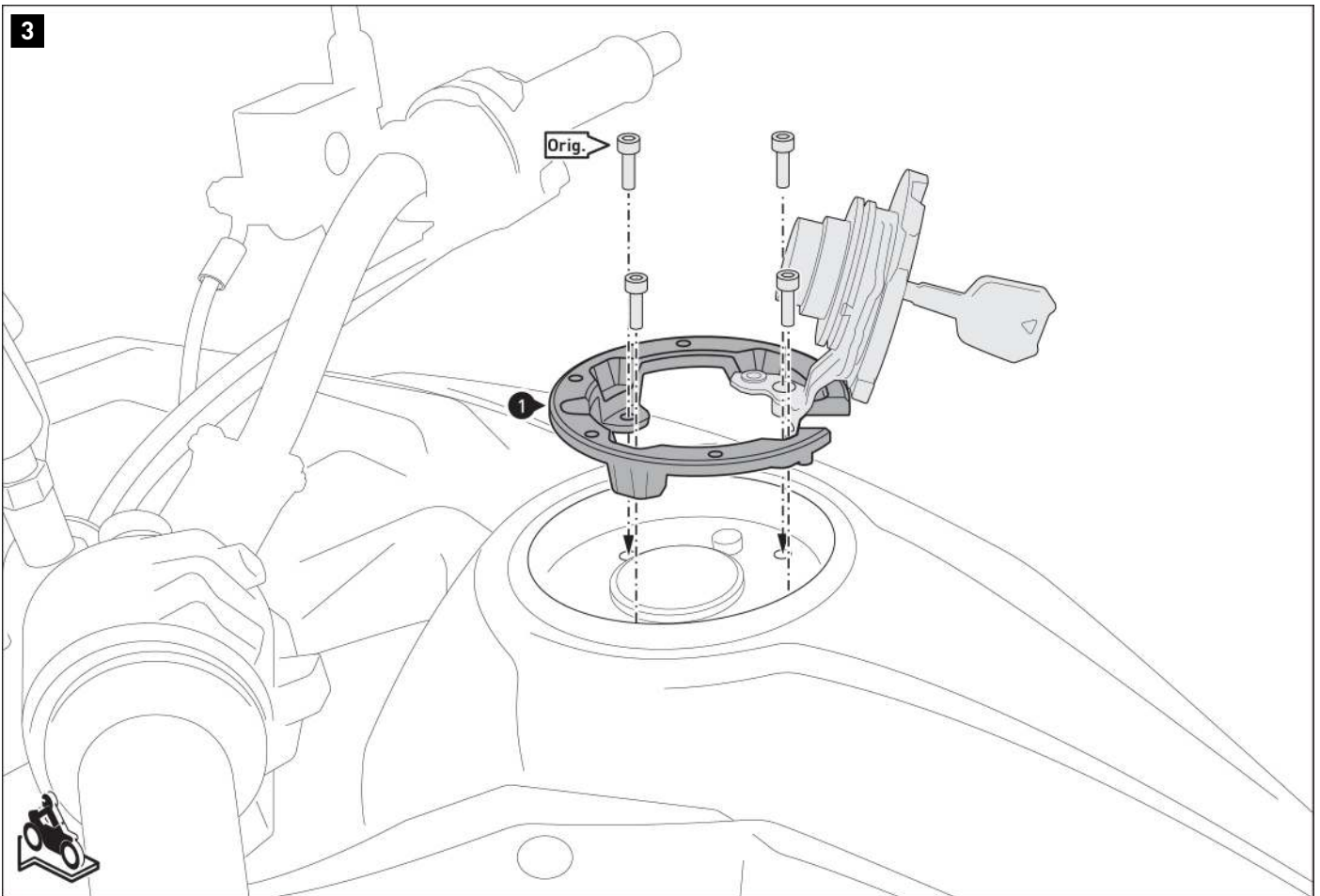

Screw the tank ring adaptor (1) onto the vehicle using the original (Orig.) screws.

**▲ WARNING: Use liquid thread locker!**

Tighten the original (Orig.) screws according to the manufacturer's instructions.



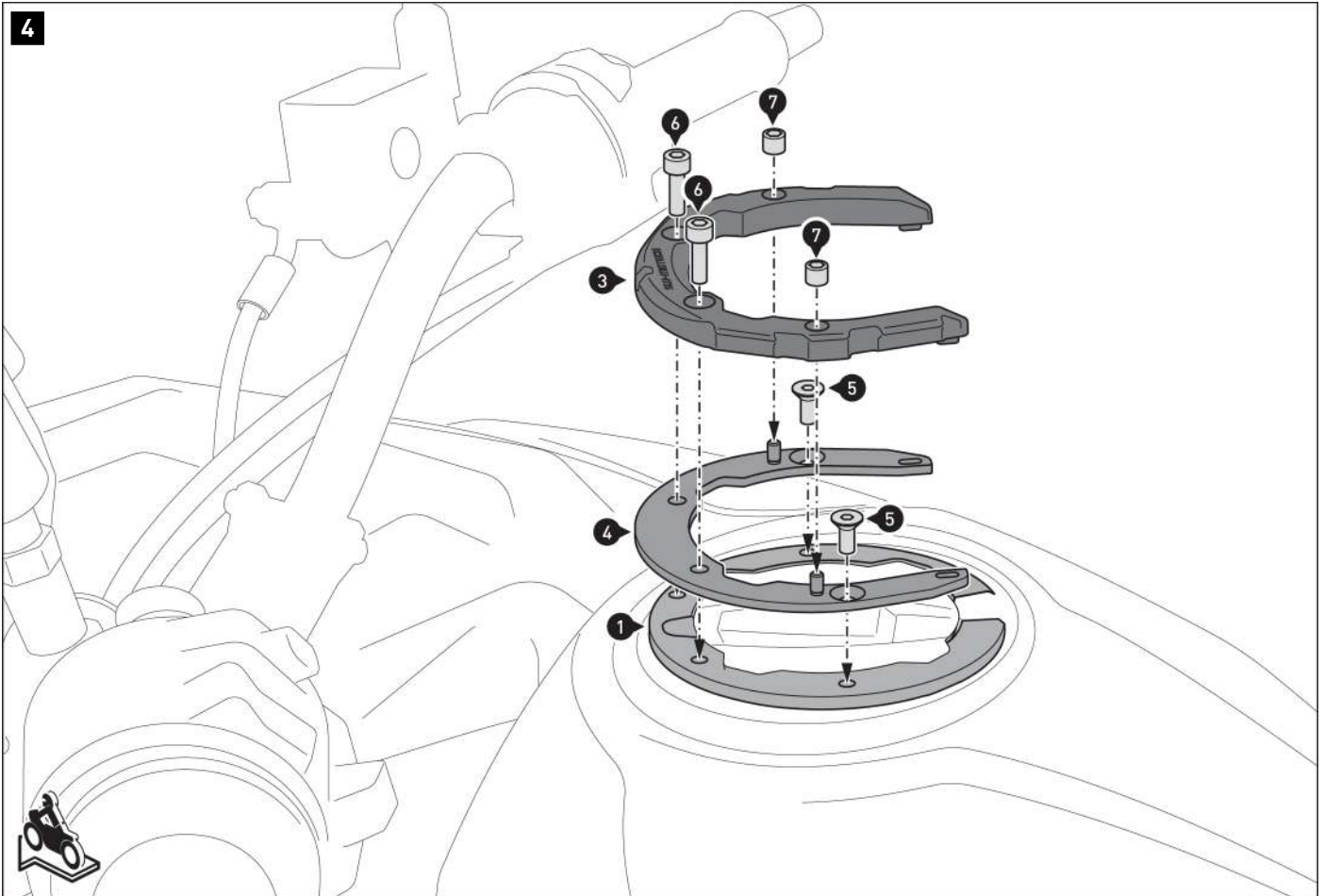

Screw the tank ring (3) onto the tank ring adaptor (1).

Pay attention to the level of resistance when screwing the tank ring, as excessive pressure can cause damage to the tank ring and tank ring adaptor.

**▲ WARNING: Use liquid thread locker!**

Tighten the screws and sleeve nuts as specified in the instructions.

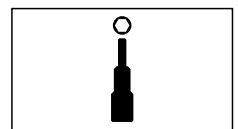
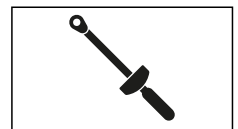

**PRODUCT-SPECIFIC NOTES**

**⚠ NOTE:** *Observe the country-specific regulations for the registration/operation of your vehicle or applicable TÜV regulations. After assembly, have parts that are subject to registration entered in the vehicle documents by your test centre.*

Art.-Nr. / Item No.: TRT.00.787.1010\*/B & TRT.00.787.1020\*/B & TRT.00.787.1030\*/B

Revision: 03 · Datum / Date: 04 - 2024

## Erhöhungselement PRO Tankring

## Heightening for PRO tank ring

**DEUTSCH** · Vielen Dank, dass Sie sich für dieses Premium-Produkt von SW-MOTECH entschieden haben. Bitte lesen und verstehen Sie alle Anweisungen, Sicherheitshinweise und Warnungen in dieser Anbauanleitung vor Montage und Nutzung des Produkts, um Verletzungen zu vermeiden. Dieses Produkt wurde für Fahrzeuge im Werkzustand entwickelt. Die Kompatibilität mit Original-Zubehörteilen bzw. den Zubehörteilen anderer Hersteller kann nicht gewährleistet werden. Besuchen Sie unseren Webshop für weitere Informationen wie Modellzuweisungen und PDF-Anbauanleitung. Erforderliche Dokumente (z. B. ABE) stehen als Download zur Verfügung. Bewahren Sie diese Anbauanleitung als Referenz auf.

SW-MOTECH übernimmt keine Haftung für Schäden, die durch eine unsachgemäße Montage und/oder Wartung verursacht wurden!

### SICHERHEITSWARNUNGSSYMBOL

**⚠** Dieses Warnsymbol wird in dieser Anbauanleitung verwendet, um vor tödlichen Gefahren, Verletzungen oder anderen Gefahren zu warnen. Die Wörter **GEFAHR**, **WARNUNG** oder **VORSICHT** werden mit diesem Warnsymbol verwendet, um wichtige Sicherheitshinweise und Informationen in Bezug auf die Montage und Nutzung dieses Produkts zu übermitteln. Diese Wörter zusammen mit dem Sicherheitswarnsymbol bedeuten:

**⚠ GEFAHR:** Weist auf eine gefährliche Situation hin, die zum Tod oder zu schweren Verletzungen führt, wenn sie nicht vermieden wird!

**⚠ WARNUNG:** Weist auf eine gefährliche Situation hin, die zum Tod oder zu schweren Verletzungen führen kann, wenn sie nicht vermieden wird!

**⚠ VORSICHT:** Weist auf eine gefährliche Situation hin, die zu leichten oder mittelschweren Verletzungen führen kann, wenn sie nicht vermieden wird!

**⚠ HINWEIS:** Wichtige Informationen, jedoch nicht in Bezug auf Todes- oder Verletzungsgefahr (nur Sachschäden)!

**⚠ WARNUNG:** Die Montage und/oder Wartung dieses Produkts erfordert fortgeschrittene technische Fähigkeiten, passende Werkzeuge und ein gutes Verständnis der Werkzeugnutzung und Drehmomentangaben. Zu Ihrer Sicherheit empfiehlt SW-MOTECH, die Montage und/oder Wartung von einem qualifizierten und zertifizierten Zweiradmechaniker durchführen zu lassen.

**⚠ WARNUNG:** Wenn Sie sich für die Eigenmontage dieses Produkts entscheiden, lesen Sie vor Montage und Nutzung die Anbauanleitung sorgfältig und vollständig durch und befolgen Sie alle Anweisungen, um schwere oder tödliche Verletzungen zu vermeiden. Beachten Sie bei der Montage und Verwendung auch alle relevanten Informationen im Fahrzeughandbuch. **WENN SIE EINEN TEIL DIESER ANBAUANLEITUNG NICHT VERSTEHEN ODER EINE ERKLÄRUNG EINER ANWEISUNG BENÖTIGEN, VERSUCHEN SIE NICHT, DIESES PRODUKT ZU MONTIEREN OHNE SW-MOTECH UM HILFE ZU FRAGEN.**

**VORBEREITUNG:** Lesen Sie die Anbauanleitung aufmerksam und stellen Sie sicher, dass alle Teile der Stückliste vorhanden sind.

**⚠ VORSICHT:** Achten Sie auf den sicheren Stand Ihres Fahrzeugs. Schalten Sie den Motor ab und ziehen Sie den Zündschlüssel. Den Motor/Auspuff bei Bedarf abkühlen lassen. Klemmen Sie die Batterie bei Arbeiten an der Elektrik ab. Verwenden Sie geeignetes Werkzeuge und tragen Sie immer eine Schutzbrille und Handschuhe. Lassen Sie sich von einer zweiten Person helfen.

**MONTAGE:** Alle vom Fahrzeug entfernten Teile und Verbindungen müssen gemäß den Angaben des Fahrzeugherstellers wieder eingebaut oder durch von SW-MOTECH gelieferte Teile und Hardware ersetzt werden.

**⚠ WARNUNG:** Sichern Sie alle Gewinde, sofern nicht anders angegeben, mit mittelstarker, flüssiger Schraubensicherung. Von SW-MOTECH nicht definierte Drehmomentspezifikationen müssen vom Fahrzeughersteller oder von einer zertifizierten Motorradwerkstatt bezogen werden!

**FUNKTIONSKONTROLLE:** Stellen Sie nach der Montage sicher, dass keine beweglichen Teile blockiert und die Funktion des Fahrzeugs nicht gestört wird. Kabel und Schläuche dürfen nicht scheuern und/oder geklemmt werden.

**⚠ WARNUNG:** Führen Sie vor Fahrtbeginn eine umfassende Funktionskontrolle durch. Prüfen Sie nach den ersten 50 km und dann regelmäßig das Anzugsmoment aller Verbindungen und den festen Sitz des Produkts. Montiertes Zubehör kann Fahrverhalten/Stabilität des Fahrzeugs verändern.

**ENGLISH** · Thank you for choosing this premium product from SW-MOTECH. Please carefully read and understand all instructions, safety messages and warnings in this mounting instructions prior to installation and use of this product to avoid injury.

This product was developed for vehicles in their factory setting. Compatibility with original accessory parts or other manufacturers' accessory parts is not guaranteed. Visit our webshop for additional information, such as application charts and PDF mounting instructions. Any other documents that may be required (e.g. ABE certifications), are also available for download at our webshop. Keep these mounting instructions as reference.

SW-MOTECH assumes no liability for damage caused by improper installation and/or maintenance work!

### SAFETY ALERT SYMBOL

**⚠** This safety alert symbol is used throughout these mounting instructions to warn of the possibility of death, bodily injury or other warnings. The words **DANGER**, **WARNING** and **CAUTION** are used with this safety alert symbol to convey important safety messages and information related to the installation and use of this product. These words along with the safety alert symbol mean:

**⚠ DANGER:** Indicates a hazardous situation that, if not avoided, will result in death or serious injury!

**⚠ WARNING:** Indicates a hazardous situation that, if not avoided, could result in death or serious injury!

**⚠ CAUTION:** Indicates a hazardous situation that, if not avoided, could result in minor or moderate injury!

**⚠ NOTICE:** Important information, but not death or injury related (property damage only)!

**⚠ WARNING:** The installation and/or maintenance of this product requires advanced mechanical skills, the proper tools, and a thorough understanding of tool use and torque specifications.

For your own safety, SW-MOTECH recommends having installation and/or maintenance carried out by a qualified and certified motorcycle mechanic.

**⚠ WARNING:** Should you choose to self-install this product, carefully and completely read all intallation and safety instructions before installation and use, and follow all the directions and safety precautions given in the mounting instructions to avoid serious injury or death. Also pay attention to all relevant information in the vehicle manual during intallation and use. **IF YOU DO NOT UNDERSTAND ANY PART OF THESE INSTRUCTIONS, OR NEED CLARIFICATION OF ANY INSTRUCTION, DO NOT ATTEMPT TO MOUNT THIS PRODUCT WITHOUT CONTACTING SW-MOTECH FOR ASSISTANCE.**

**PREPARATION:** Read the mounting instructions carefully and make sure that all items of the parts list are included.

**⚠ CAUTION:** Make sure that your vehicle is parked safely and cannot fall over. Turn off the engine and remove the ignition key. Let the engine/exhaust cool off if necessary. Disconnect the vehicle battery when working on the electrical system. Use appropriate tools and wear always safety glasses and hand protection. Have another person help you.

**MOUNTING:** All parts and connections removed from the vehicle must be reinstalled in accordance with the vehicle manufacturer specifications or replaced by parts and hardware delivered by SW-MOTECH.

**⚠ WARNING:** Secure all threads, unless otherwise specified, with medium-strong strength liquid thread locker. Torque specifications undefined by SW-MOTECH must be obtained from the vehicle manufacturer or by a certified motorcycle workshop!

**FUNCTION CHECK:** After installation also make sure that no moving parts are obstructed, and function of the vehicle is not hindered in any way. Cables and hoses must not rub and/or be pinched.

**⚠ WARNING:** Before starting to ride, perform a comprehensive check of all functions. After the first 50 km and then at regular intervals, check the tightening torque of all connections and the proper fit of the product. Installed accessories can change driving behavior/stability of the vehicle.

Konfektionierung durch / Packed by:

Datum der Konfektionierung / Date of packaging:



SW-MOTECH GmbH & Co. KG

Ernteweg 7-10  
35282 Rauschenberg  
Germany

Tel. / phone + 49 (0)6425 / 8168 - 050

Fax / fax + 49 (0)6425 / 8168 - 10

info@sw-motech.com

www.sw-motech.com



**Erhöhungselement 6 mm**  
**Height increasing element 6 mm**  
 TRT.00.787.1010\*/B

**⚠️ WARNUNG: Tragen Sie immer Augen- und Handschutz!**

**⚠️ WARNUNG: Verwenden Sie immer geeignetes Werkzeug!**

Verschrauben Sie das Erhöhungselement (1) **locker** zwischen dem Oberring und der Justierungsplatte des Tankrucksacks (siehe **Schritt [3]** in der Anbauanleitung des PRO Oberrings). Verwenden Sie die dem Oberring beiliegenden Schrauben (\*).

**⚠️ WARNUNG: Verwenden Sie flüssige Schraubensicherung mit geringer Festigkeit!**

Ziehen Sie die Schrauben noch nicht an (siehe **Schritt [8]** in der Anbauanleitung des PRO Oberrings).

**⚠️ WARNUNG: Always wear eye and hand protection!**

**⚠️ WARNUNG: Always use appropriate tools!**

Attach the height increasing element (1) **loose** between the upper ring and the tank bag adjustment plate (refer to **step [3]** of the mounting instructions of the PRO upper ring). Use the screws (\*) included to the upper ring.

**⚠️ WARNUNG: Use low strength liquid thread locker!**

Do not fully tighten the screws yet [refer to **step [8]** of the mounting instructions of the PRO upper ring].

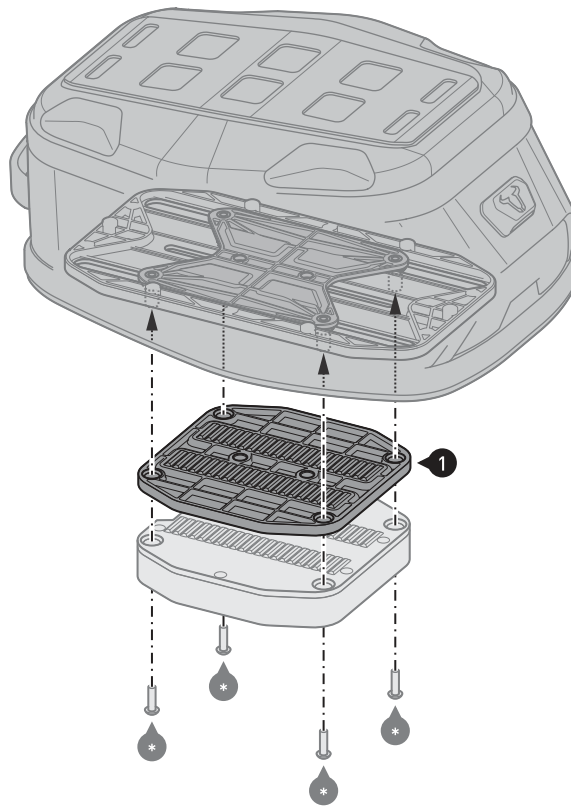

**WARNUNG / WARNING** ⚠️

Verwenden Sie zum Anziehen der Schrauben das in **DIESER** Anbauanleitung vorgegebene Anzugsmoment von 1,5 Nm, **NICHT** das Anzugsmoment aus der Anbauanleitung der PRO Tankrucksäcke! **BRUCHGEFAHR!**

To tighten the screws, use the tightening torque of 1.5 Nm specified in **THESE** mounting instructions, **NOT** the tightening torque from the mounting instructions of the PRO tank bags! **BREAK HAZARD!**

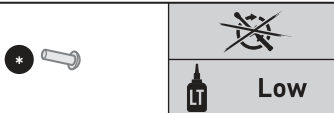

Der gezeigte Tankrucksack dient als Beispiel. / The shown tank bag is an example.

**Erhöhungselement 12 mm**  
**Height increasing element 12 mm**  
 TRT.00.787.1020\*/B

**⚠️ WARNUNG: Tragen Sie immer Augen- und Handschutz!**

**⚠️ WARNUNG: Verwenden Sie immer geeignetes Werkzeug!**

Verschrauben Sie die Erhöhungselemente (1) **locker** zwischen dem Oberring und der Justierungsplatte des Tankrucksacks (siehe **Schritt [3]** in der Anbauanleitung des PRO Oberrings). Verwenden Sie die Schrauben (2).

**⚠️ WARNUNG: Verwenden Sie flüssige Schraubensicherung mit geringer Festigkeit!**

Ziehen Sie die Schrauben noch nicht an (siehe **Schritt [8]** in der Anbauanleitung des PRO Oberrings).

**⚠️ WARNUNG: Always wear eye and hand protection!**

**⚠️ WARNUNG: Always use appropriate tools!**

Attach the height increasing elements (1) **loose** between the upper ring and the tank bag adjustment plate (refer to **step [3]** of the mounting instructions of the PRO upper ring). Use the screws (2).

**⚠️ WARNUNG: Use low strength liquid thread locker!**

Do not fully tighten the screws yet [refer to **step [8]** of the mounting instructions of the PRO upper ring].

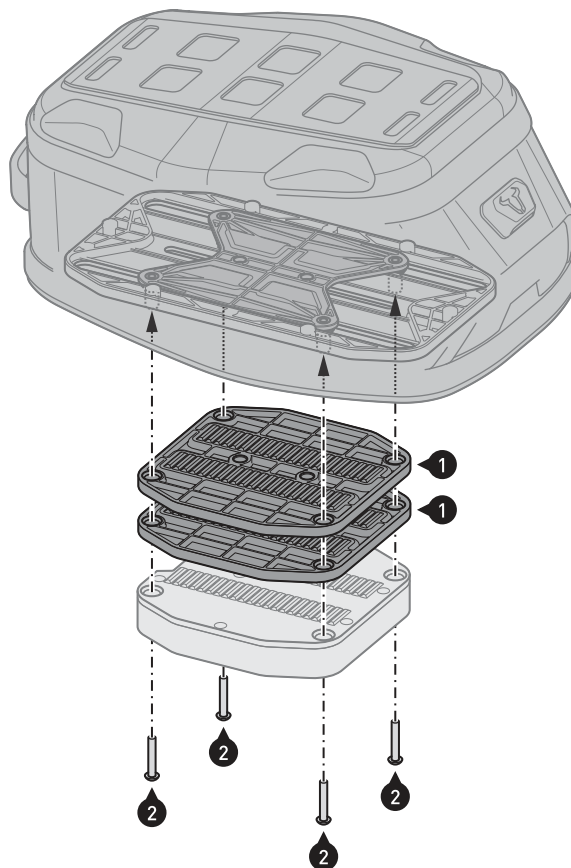

**WARNUNG / WARNING** ⚠️

Verwenden Sie zum Anziehen der Schrauben das in **DIESER** Anbauanleitung vorgegebene Anzugsmoment von 1,5 Nm, **NICHT** das Anzugsmoment aus der Anbauanleitung der PRO Tankrucksäcke! **BRUCHGEFAHR!**

To tighten the screws, use the tightening torque of 1.5 Nm specified in **THESE** mounting instructions, **NOT** the tightening torque from the mounting instructions of the PRO tank bags! **BREAK HAZARD!**

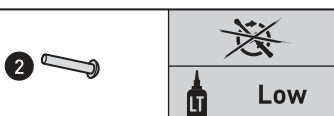

Der gezeigte Tankrucksack dient als Beispiel. / The shown tank bag is an example.

**Erhöhungselement 18 mm**  
**Height increasing element 18 mm**  
 TRT.00.787.1030+/B

**⚠️ WARNUNG: Tragen Sie immer Augen- und Handschutz!**

**⚠️ WARNUNG: Verwenden Sie immer geeignetes Werkzeug!**

Verschrauben Sie die Erhöhungselemente (1) **locker** zwischen dem Oberring und der Justierungsplatte des Tankrucksacks (siehe **Schritt [3]** in der Anbauanleitung des PRO Oberrings). Verwenden Sie die Schrauben (2).

**⚠️ WARNUNG: Verwenden Sie flüssige Schraubensicherung mit geringer Festigkeit!**

Ziehen Sie die Schrauben noch nicht an (siehe **Schritt [8]** in der Anbauanleitung des PRO Oberrings).

**⚠️ WARNUNG: Always wear eye and hand protection!**

**⚠️ WARNUNG: Always use appropriate tools!**

Attach the height increasing elements (1) **loose** between the upper ring and the tank bag adjustment plate (refer to **step [3]** of the mounting instructions of the PRO upper ring). Use the screws (2).

**⚠️ WARNUNG: Use low strength liquid thread locker!**

Do not fully tighten the screws yet (refer to **step [8]** of the mounting instructions of the PRO upper ring).

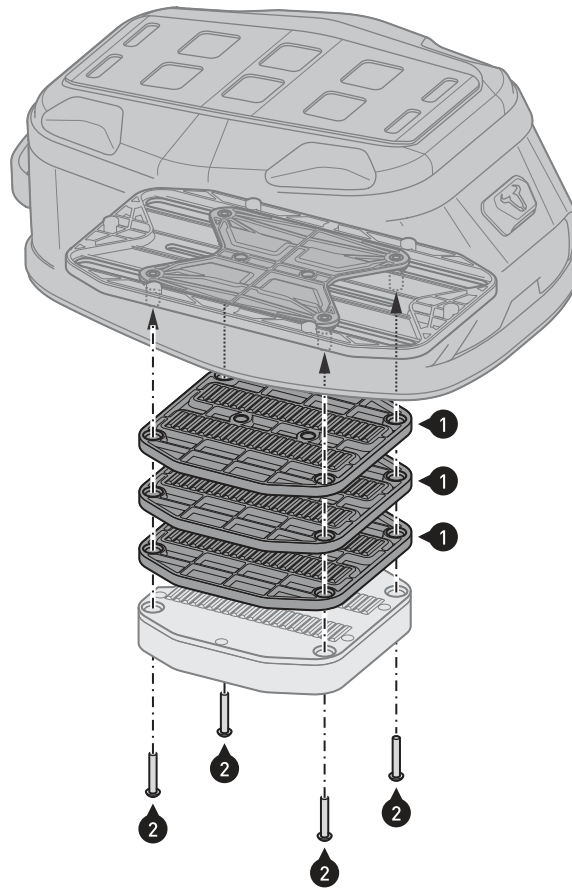

**WARNUNG / WARNING**

Verwenden Sie zum Anziehen der Schrauben das in **DIESER** Anbauanleitung vorgegebene Anzugsmoment von **1,5 Nm**, **NICHT** das Anzugsmoment aus der Anbauanleitung der PRO Tankrucksäcke! **BRUCHGEFAHR!**

To tighten the screws, use the tightening torque of **1.5 Nm** specified in **THESE** mounting instructions, **NOT** the tightening torque from the mounting instructions of the PRO tank bags! **BREAK HAZARD!**

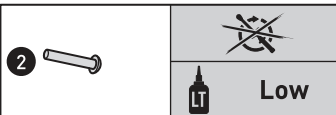

Der gezeigte Tankrucksack dient als Beispiel. / The shown tank bag is an example.

**PRODUKTSPEZIFISCHE HINWEISE**

**⚠️ HINWEIS:** Beachten Sie die landesspezifischen Vorschriften für Zulassung/Betrieb Ihres Fahrzeugs bzw. anwendbare TÜV-Vorschriften. Lassen Sie eintragungspflichtige Teile nach Montage durch Ihre Prüfstelle in die Fahrzeugpapiere eintragen.

**PRODUCT SPECIFIC INFORMATION**

**⚠️ NOTICE:** Observe the country-specific regulations concerning vehicle registration/operation as well as TÜV regulations if applicable. If required, register installed parts in the vehicle documents through an appropriate inspection authority.

Item number: TRT.00.787.80000/B

Revision: 00 · Date: 03 - 2026

## Extension ring for PRO adapter ring 01

🕒 ~ 0.25 h.

EASY      DIFFICULT

**ENGLISH** Thank you for choosing this premium product from SW-MOTECH. Visit our online shop for more information (e.g. model assignments). Required documents (e.g. national type approval) are available there for you to download.

Please read and understand all the instructions, safety information and warnings in these mounting instructions before mounting and using the product in order to avoid injury and damage. Keep these mounting instructions for reference.

This product was developed for vehicles in factory condition. Compatibility with original accessories or accessories from other manufacturers cannot be guaranteed.

These mounting instructions have been prepared to the best of our current knowledge. No legal claims relating to accuracy can be made. Errors and omissions excepted. We reserve the right to make technical and design changes. The copyright is held by SW-MOTECH.

## SAFETY WARNING SYMBOL

⚠ This warning symbol is used in these mounting instructions to warn of deadly dangers, injuries or other hazards. The words **DANGER**, **WARNING** or **CAUTION** are used as part of this warning symbol to convey important safety messages and information relating to the installation and use of this product. These words, together with the safety warning symbol, mean:

⚠ **DANGER:** Indicates a hazardous situation which, if not avoided, will result in death or serious injury!

⚠ **WARNING:** Indicates a hazardous situation which, if not avoided, may result in death or serious injury!

⚠ **CAUTION:** Indicates a hazardous situation which, if not avoided, may result in minor or moderate injury!

⚠ **NOTE:** Important information, but not relating to a risk of death or injury (property damage only)!

## GENERAL INFORMATION

⚠ **WARNING:** Assembly and/or maintenance of this product requires advanced technical skill, appropriate tools, and a good understanding of tool usage and torque specifications. For your own safety, SW-MOTECH recommends having the assembly and/or maintenance carried out by a qualified and certified motorcycle workshop.

⚠ **WARNING:** If you do choose to assemble this product yourself, carefully and fully read the mounting instructions before assembly and use, and follow all instructions to avoid serious injury or death. Also observe all relevant information in the vehicle manual when mounting or using the product. IF YOU DO NOT UNDERSTAND ANY PART OF THESE MOUNTING INSTRUCTIONS OR NEED AN EXPLANATION AS TO A SPECIFIC INSTRUCTION, DO NOT ATTEMPT TO INSTALL THIS PRODUCT WITHOUT CONSULTING SW-MOTECH FOR ASSISTANCE!

**PREPARATION:** Read the mounting instructions carefully and make sure that all parts on the parts list are available.

⚠ **CAUTION:** Ensure that your vehicle is standing securely. Switch off the engine and remove the ignition key. Allow the engine/exhaust to cool down if necessary. Disconnect the battery when working on the electrical system. Only use proper tools and always wear safety goggles and gloves during assembly and maintenance. Have a second person help you with assembly and maintenance.

**ASSEMBLY:** All parts and connections removed from the vehicle must be reinstalled according to the vehicle manufacturer's specifications or replaced with parts and hardware supplied by SW-MOTECH.

⚠ **WARNING:** Secure all threads with a medium-strength liquid threadlocker, unless otherwise specified.

⚠ **DANGER:** Tightening torques not defined by SW-MOTECH must be obtained from the vehicle manufacturer or a certified motorbike workshop.

**FUNCTIONAL CHECK:** After mounting the product, ensure that no moving parts are obstructed and that the function of the vehicle is not impeded. Cables and hoses must not rub against each other and/or be hindered in any way.

⚠ **WARNING:** Carry out a comprehensive functionality check before you start to drive. Check the tightening torque of all connections and the tight fit of the product after the first 50 km and then at regular intervals. Mounted accessories can change the handling and stability of the vehicle.



SW-MOTECH GmbH & Co. KG  
Ernteweg 7-10  
35282 Rauschenberg  
Germany



✉ info@sw-motech.com  
🌐 www.sw-motech.com



Take note of the symbols and what they mean in the ASSEMBLY section. If the term OEM appears in the ASSEMBLY section, the vehicle manufacturer's specifications must be observed and applied.



If you have any questions, please don't hesitate to contact our Customer Service team or our distributors. You can find our telephone number and a list of our distributors in our online shop:

**[www.sw-motech.com](http://www.sw-motech.com)**

1



TRT.00.787.045.11

 1/1

1

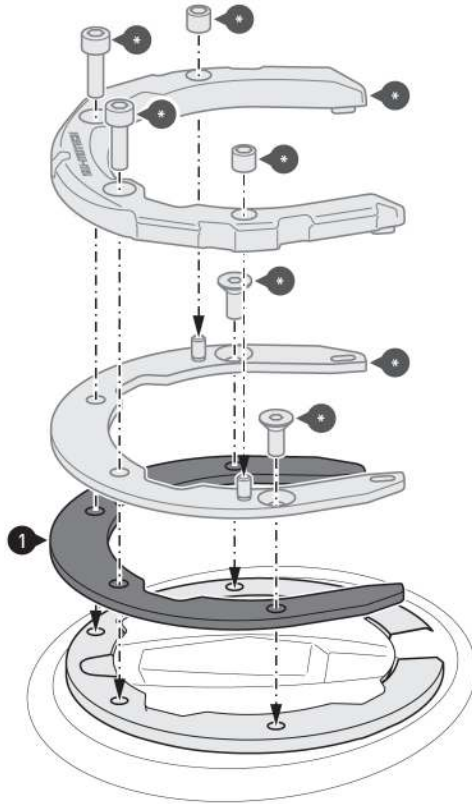

- ▲ **WARNING: Always wear eye and hand protection!**
- ▲ **WARNING: Always use suitable tools!**

Screw the height increasing element [1] underneath the mounting ring (-). Use the attachments included with the PRO tank ring (-).

- ▲ **WARNING: Use liquid threadlocker!**
- Tighten the screws (-) according to the vehicle manufacturer's specifications.

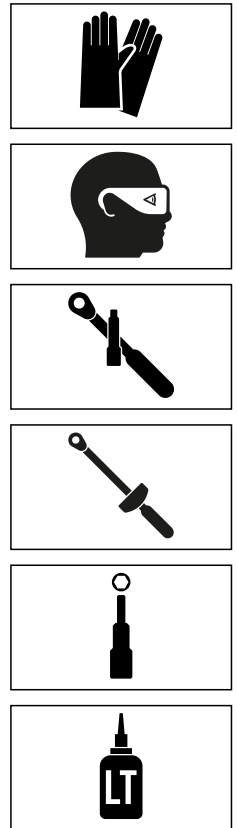

**PRODUCT-SPECIFIC NOTES**

**⚠ NOTE** :Observe the country-specific regulations for the registration/operation of your vehicle and any applicable TÜV regulations. Have any parts requiring registration entered into your vehicle documents by your inspection centre after they have been installed.